

B/122-ELAST.



Macchina automatica per applicazione elastico su cartelle e copertine di agende

L'operatore ha la possibilità di impostare mediante un "touch screen" la lunghezza desiderata dell'elastico e programmare l'abbondanza in base allo spessore dell'agenda da chiudere, mentre l'interasse dei due occhielli di fissaggio dell'elastico si imposta mediante un apposito volantino che regola lo spostamento di una delle due teste da un minimo di 110 mm a un massimo di 350 mm. Quindi, dopo queste semplici operazioni si avvia la macchina mediante il pedale di comando.

Automatic machine for the application of the elastic on folders and on the covers of agendas

The machine is equipped with a touch screen on which the operator can set the desired length of the elastic. The distance between the eyelets is adjusted by a special wheel which allows to change the position of the heads from min. distance of 110 mm up to 350 mm. Once the dimensions are set, it is sufficient to press the pedal to start the production process.

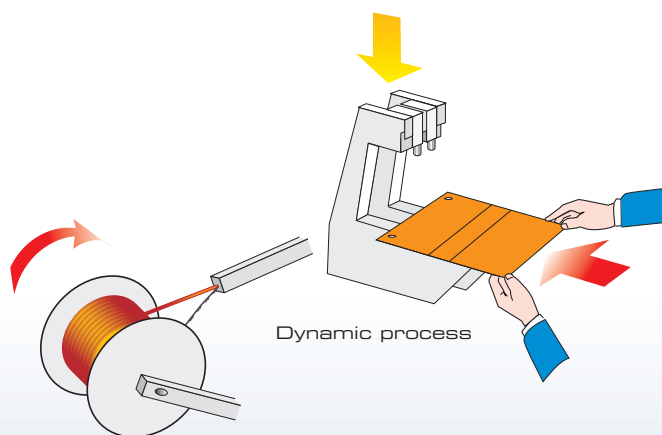
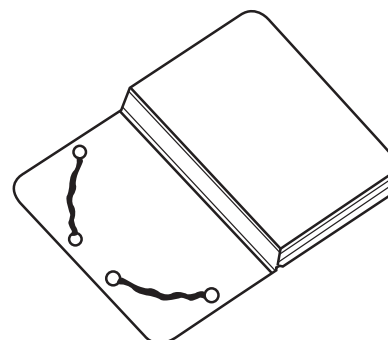
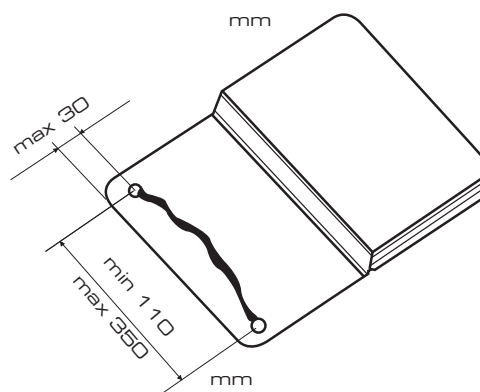
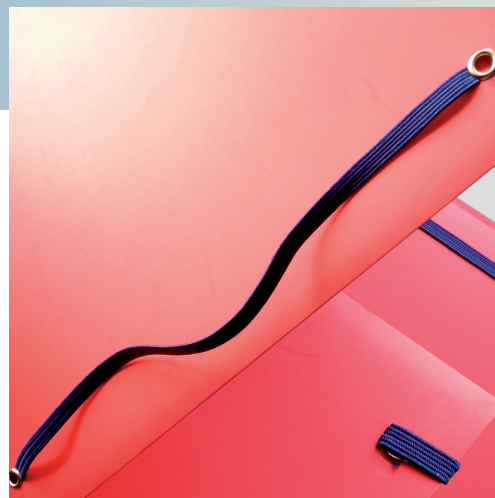

- Larghezza elastico: Piatto da 5 a 8 mm.
- Occhiello: A richiesta.
- Produzione: 20 cicli/minuto*.
- Voltaggio: 220 Volt monofase 200 W.
- Consumo pneumatico: 8 NL / ciclo (6 bar)
- Dimensioni: L= 1000 mm; P= 650 mm; H= 1400 mm.
- Peso: Kg. 120

- Flat elastic width: 5 up to 8 mm.
- Eyelets: On request.
- Capacity: Up to 20 pieces/minute*.
- Voltage: 220 Volt single phase.
- Compressed air: 8 NL / cycle (6 bar)
- Dimensions: L= 1000 mm; P= 650 mm; H= 1400 mm.
- Weight: Kg. 120

* Production capacity of every machine depends on sizes, type of materials, glues and operator skill
IML reserves the right to change technical specifications without notice.

VARIOUS PRODUCTS